

JDN Ultra Low Monorail Hoists

Where loads have to be lifted and transported in extremely reduced spaces, the JDN Ultra-Low Monorail Hoists provide the ideal solution. For example the Ultra-Low Monorail Hoist with a load capacity of 6t has a headroom of only 230mm.

Features

- Ideally suited for working in hazardous areas-explosion risk.
- JDN Ultra Low Monorail Hoists UH are insensitive to humidity, dust and temperatures from 20 degrees up to +70 degrees.
- Extremely low headroom
- Low Air consumption.
- Available with increased spark protection.

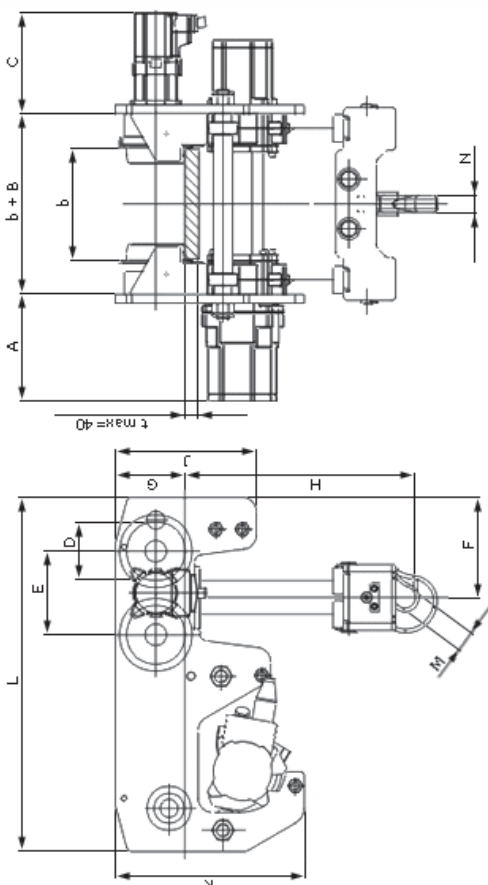

www.pacifichoists.com.au

Dimensions (see diagram over page)

TYPE	A	B	C	D	E	F	G	H	J	K	L	M	N
UH4	195	200	284	165	236	330	197.5	230	400	535	1000	40	51
UH6	305	200	284	165	236	330	197.5	230	400	535	1000	40	51
UH8	195	200	284	165	236	283	197.5	295	400	535	1000	44	66
UH12	305	200	284	165	236	283	197.5	295	400	535	1000	44	66
UH16	305	200	284	165	236	283	197.5	334	400	535	1000	53	82

Specifications

Type		UH 4	UH 6	UH 8	UH 12
Rated capacity	tonne	4	6	8	12
Number of chain strands		2	2	4	4
Motor Output	kW	2.5	2.5	2.5	2.5
Air pressure	bar	6	6	6	6
Lifting speed at full load	m/min	3.0	2.0	1.4	0.9
Lowering Speed at full load	m/min	7.5	5.2	3.6	2.5
Air consumption at full load	m3/min	4.0	4.0	4.0	4.0
Weight and standard lift height and control length	kg	460	470	540	550
Chain Dimension	mm	13x36	13x36	13x36	13x36
Weight of 1m chain	kg	3.8	3.8	3.8	3.8
Standard Lift	m	3	3	3	3
Length of control at standard lift	m	2	2	2	2
Noise level at full load lifting	db	78	78	78	78
Noise level at full load lowering	db	80	80	80	80

Your nearest distributor;

The information contained in this flyer is to be used as a guide only, specifications subject to change without notice. All Materials Handling/Lifting jobs should be assessed individually. Pacific Hoists products are NOT to be used for lifting or lowering person/s.

PACIFIC HOISTS PTY LTD

www.pacifichoists.com.au



Head Office
24 Foundry Road
Seven Hills NSW 2147
Tel: +61 2 8825 6900
Fax: +61 2 8825 6999
Email: sales@pacifichoists.com.au

Western Australia
3/39 Tullock Way
Canning Vale WA 6155
Tel: +61 8 9456 4140
Fax: +61 8 9456 4142
Email: sales@pacifichoists.com.au

New Zealand
11 Druces Road
Manukau City South Auckland
New Zealand
Tel: +64 9 263 5566
Fax: +64 9 263 5567
Email: info@pacifichoists.co.nz

