

# Pacific Brake Hand Winches

The cost-effective solution for a wide variety of applications. Pacific Brake Hand Winches can be used for both pulling and lifting applications.

## Features

- Positive Weston-style brake will hold the load in any position.
- Compact, lightweight and rugged construction.
- Mechanical components enclosed for protection and safety.
- Baked enamel or G304 Stainless Steel for corrosion protection.
- Rope to drum fixing clamp provided.
- Heat-treated gears.
- Strong removable handles.
- High precision construction minimises gear noise.
- AS1418.2 Compliance applies when correctly fitted with approved Wire Rope and Fittings.
- Noiseless BHW1200 available.
- Worm drive version available.



DOUBLE BRAKE PAWL FOR EXTRA SAFETY ON BHW1800 & BHW2600



GEARS ARE STRONG AND DURABLE AND ELECTROPLATED FOR EXTRA CORROSION RESISTANCE



[www.pacifichoists.com.au](http://www.pacifichoists.com.au)

## Dimensions

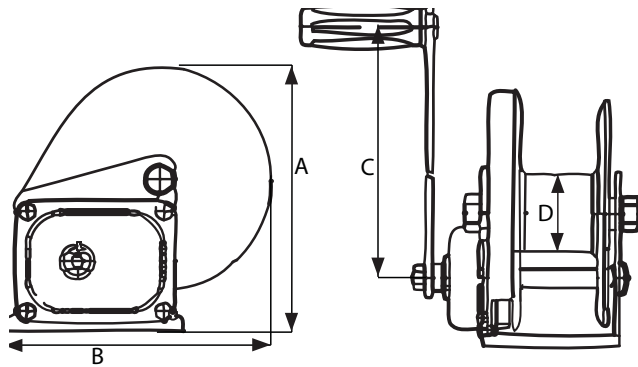

TYPE	BWH800	BWH1200	BWH1800	BWH2600
A	160	160	204	217
B	150	150	245	295
C	160	160	300	300
D	50	50	70	82

## Hole Alignment

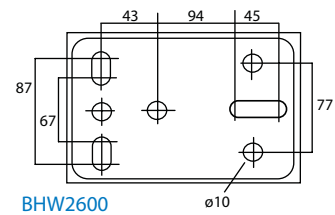
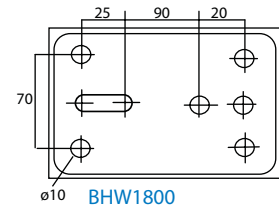
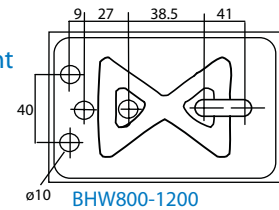

## Specifications

Model	BHW800	BHW1200	BHW1800	BHW2600	SF2200	HW1500
Capacity Pull-Lift kg	370-180	545-270	820-410	1200-600	1700-850	680
Hand force required kg	14.5	15	22	19	16	4.5
Gear Ratio	4.1:1	4.1:1	5.1	10.1	22.2:1	41:1
Unit height A mm	160	160	204	217	214	161
Unit length B mm	150	190	245	295	238	173
Handle length C mm	160	210	320	320	300	195
Hub diameter D mm	Ø40	Ø50	Ø70	Ø80	Ø60	Ø48
Base Plate wxl mm	89x138	89x138	107x193	127x270	238 X 223	153 X 130
Unit weight kg	3	3.3	8	10.3	13.5	4.9
Wire Rope ømmxm	Ø4x36	Ø5x23	Ø7x24	Ø8x18	Ø8	Ø4
Finish - Powder coated	√	√	√	√	√	√
Finish - Stainless steel	-	√	√	√	-	-
Finish - Noiseless	-	√	-	-	-	-

Your nearest distributor;

The information contained in this flyer is to be used as a guide only, specifications subject to change without notice. All Materials Handling/Lifting jobs should be assessed individually. Pacific Hoists products are NOT to be used for lifting or lowering person/s.

PACIFIC HOISTS PTY LTD

[www.pacifichoists.com.au](http://www.pacifichoists.com.au)



Head Office  
24 Foundry Road  
Seven Hills NSW 2147  
Tel: +61 2 8825 6900  
Fax: +61 2 8825 6999  
Email: [sales@pacifichoists.com.au](mailto:sales@pacifichoists.com.au)

Western Australia  
3/39 Tullock Way  
Canning Vale WA 6155  
Tel: +61 8 9456 4140  
Fax: +61 8 9456 4142  
Email: [sales@pacifichoists.com.au](mailto:sales@pacifichoists.com.au)

New Zealand  
11 Druces Road  
Manukau City South Auckland  
New Zealand  
Tel: +64 9 263 5566  
Fax: +64 9 263 5567  
Email: [info@pacifichoists.co.nz](mailto:info@pacifichoists.co.nz)



QUALITY LIFTING SOLUTIONS